

L I F T   C A R S



# L I F T C A R S

## THE 210 | SERIES

### An IMEM lift guarantees top quality and high performance

**European manufacture & designed-for-purpose technology.** Every IMEM lift is designed and manufactured from start to finish in our own production plants in Santander, on Spain's north coast.

**Top-quality engineering.** Our lift systems have a well-founded reputation for their high-quality manufacture, use of top brand components, robust mechanical systems and excellent reliability.

Which is why we supply them with a **mechanical guarantee of up to three years.**

**Electrical simplicity.** We supply the electrical components of our lift systems pre-tested, with all the connectors preassembled, which saves our customers time and money, eliminates faults and simplifies assembly work.

**Unbeatable specifications.** Our lift systems incorporate our unique and exclusive **Direct Approach System**; which ensures perfect levelling at every landing and is supplied as standard. IMEM lifts deliver exceptional precision and ride comfort, and reduced waiting times which are well ahead of market standards.

**Availability and fast delivery of spare parts.** We keep a huge range of spare parts and components in storage for all existing lift types and technologies to respond rapidly to customer needs in any part of the world.

**Excellent technical support service.** We offer our customers a comprehensive technical support service - both electrical and mechanical - from the initial assembly phase through installation and start-up to after-sales, to ensure that they get the best possible performance from each and every lift system.

**Exceptional delivery times:** our manufacturing and delivery times are among the most competitive ones you can find in the market with the best guarantees.



# THE 210 SERIES

The 210 series offers lift cars perfectly suited to all kinds of building projects, a functional design based on modular construction, offering a wide choice of up-to-date colours and built with high-quality materials chosen for their durability and resistance to wear.

## CAR CONSTRUCTION

- The lift cars in **the 210 series** are built in **sheet steel** finished with **plastic laminates** in a wide range of colours or in **stainless steel** with a choice of different textures.
- The **car lighting** can be direct using **LED spots** or **light panels**, or indirect using **fluorescent lights** with a range of different **suspended ceiling panels** available.
- The **car doors** are supplied with a **stainless steel finish in a choice of textures**, and the **car fronts** can also have a **stainless steel finish in a range of textures**, as required.
- The upper and lower **skirtings** are supplied with a **stainless steel finish** in different textures.
- **The car flooring** can be finished in **hardwearing black rubber**, in **granites** of different shades, in **marble** and in other resistant materials such as **aluminium, stainless steel** or **reinforced vinyl**.
- **The handrails** are supplied with a stainless steel finish, in a range of different configurations, according to customer choice.
- **The mirror** can be supplied to fill **one-third, one-half** or **the entire width** of the car's rear wall, or we can supply the car **without a mirror**.

## THE 210 SERIES OFFERS

- **Great design and the versatility to fit in well with any building.** It is very hard to go wrong with **the 210 model series**: these lift cars are designed so that they can be harmoniously adapted to any building environment.
- **Unlimited decorative possibilities**, with numerous combinations available of colour, ceiling finish, flooring and handrail choices.
- **Rated loads available to 1.275 Kg.**
- **Simplicity:** the lift car is supplied with the lighting and operating panel pre-wired. Unit assembly is easy and quick, and each is delivered with all the detailed information and documentation required.
- **Cars** suitable for lift systems compliant with the 2014/33/UE directive. Compliance with the EN 81-70 standard is available on request.
- **Customized individual Design:** special car walls, floors, and ceiling finishes available on demand. Also available prepared to accept lighting or flooring by others.









# THE 220 | SERIES



THE 210 SERIES

 **IMEM**  
L I F T S



# THE 220 SERIES

The 220 series offers lift cars which are robust and hardwearing, and ideal for installation in lift systems designed to carry heavy loads, whether goods or passengers. The 220 series offers a wide-ranging choice of decorative options suitable for settings such as shopping centres, airports, public buildings or industrial installations of all kinds.

## CAR CONSTRUCTION

- The lift cars in **the 220 series** are built in **sheet steel** finished with **plastic laminates** in a wide range of colours or in **stainless steel** with a choice of different textures.
- **The car lighting** is direct using **LED spots** or **fluorescent lights**.
- **Ceilings** and **hatchways** are finished in white skinplate or stainless steel.
- The **car doors** are supplied with a **stainless steel finish in a choice of textures**, and the car fronts can also be finished in **stainless steel, in a range of textures**, as required.
- The upper and lower **skirtings** are supplied with a **stainless steel finish** in different textures.
- The car **flooring** can be finished in **hardwearing rubber**, in **granites** of various different shades, in **marble** and in other resistant materials such as **aluminium, stainless steel** or **reinforced vinyl**. Or it can be supplied **ready to be finished according to each customer's particular requirements**.
- **The handrails** are supplied with a stainless steel finish, in a range of different configurations, according to customer choice.
- **The mirror** can be supplied to fill **one-half** of the car's rear wall (maximum dimensions: 1.400mm width, 1.180mm height) or **the entire wall** (fitted in two pieces).

## THE 220 SERIES OFFERS

- **Excellent performance in the transport of heavy loads:** **the 220 series** has been designed to respond effectively to all the vertical transport needs of buildings with high volumes of traffic.
- **Proven durability and resistance:** **the 220 series** lift cars are sturdily built and reinforced to comfortably deal with intensive work conditions over a long period of time. The construction materials used are of top quality and distinguished by their durability.
- **Additional protective measures:** the cars can be reinforced with buffer rails and kick plates for greater durability and with any other materials and components requested by the customer to maximise their effectiveness over time.
- **Rated loads available** from 1.300 to 4.000 Kg.
- **Simplicity:** the lift car is supplied with the lighting and operating panel pre-wired. Unit assembly is easy and quick, and each is delivered with all the detailed information and documentation required.
- **Cars** suitable for lift systems compliant with the 2014/33/UE directive. Compliance with the EN 81-70 standard, among others, is available on request.
- **Customized individual Design:** special car walls, floors, and ceiling finishes available on demand. Also available prepared to accept lighting or flooring by others.









# CAR FINISHES 210 & 220

## FLOORING

### Rubber flooring

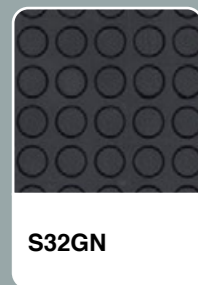

S32GN

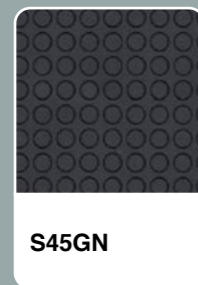

S45GN

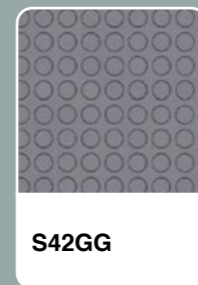

S42GG

### Aluminum flooring

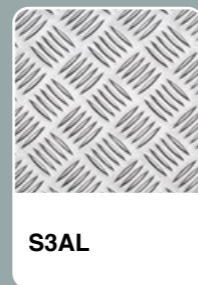

S3AL

### Marble flooring

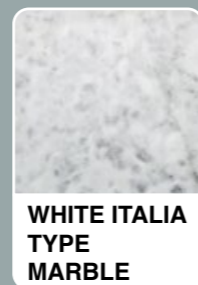

WHITE ITALIA  
TYPE  
MARBLE

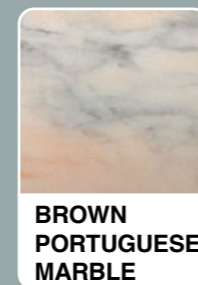

BROWN  
PORTUGUESE  
MARBLE

### Stainless steel flooring

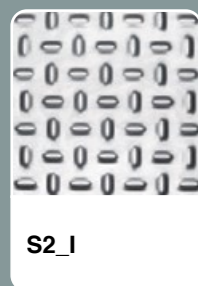

S2\_I

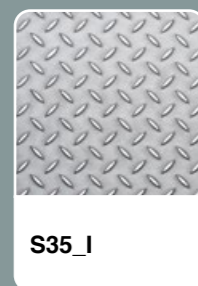

S35\_I

### Granite flooring



PERL  
GRAY  
GRANITE

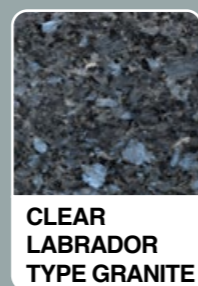

CLEAR  
LABRADOR  
TYPE GRANITE

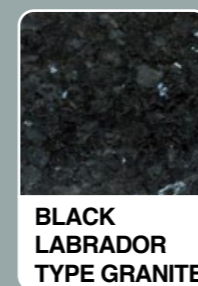

BLACK  
LABRADOR  
TYPE GRANITE

## SKINPLATE TYPE WALLS



P222



P260

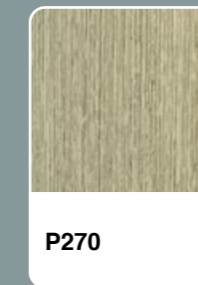

P270

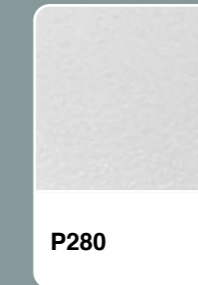

P280

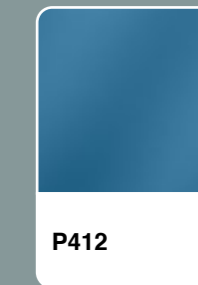

P412



P422



P432

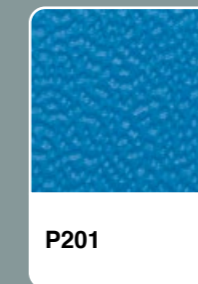

P201

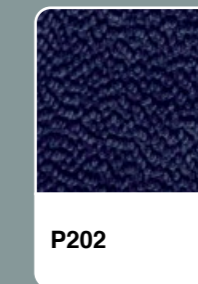

P202



P203



P204



P205



P206



P208

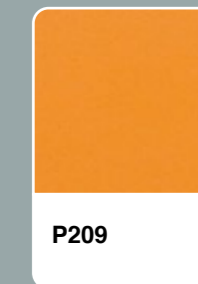

P209

## STAINLESS STEEL WALLS



INOX

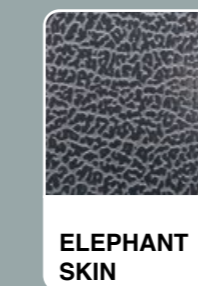

ELEPHANT  
SKIN

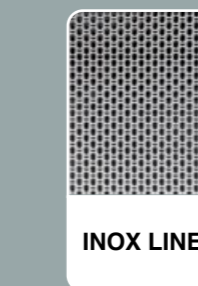

INOX LINEN



# CAR LIGHTING

## 210 SERIES



L350



L760



L750

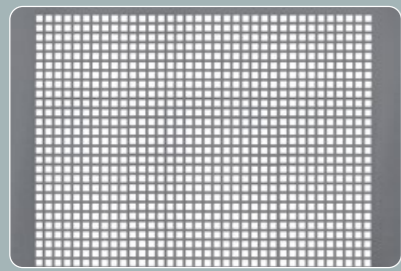

\*REF. 401



SPOT LED

## 220 SERIES



F-E



F-S



SPOT LED

\* Available as RAL9005 sprayed or stainless steel executed

# BUFFER RAILS

## 220 SERIES



PL\_MS



PL\_PVC



PL-I

# STAINLESS STEEL HANDRAILS



PSI 1



PSI 2



PSI 3



PSI 4



# OPERATION STATIONS, PUSH BUTTONS & INDICATORS

## CAR OPERATION PANEL



\*BCCE

## LANDING OPERATION STATION



## SURFACE MOUNTED LANDING INDICATORS



## PUSH BUTTONS



## SPECIAL FUNCTIONS KEY SWITCHES



## FLUSH MOUNTED LANDING INDICATORS

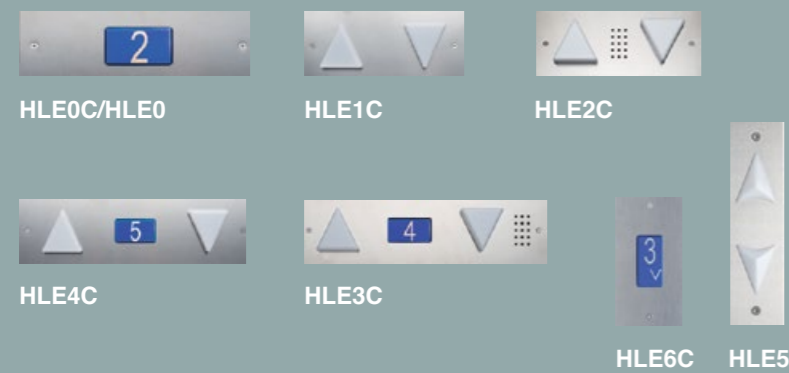

## DISPLAYS



# THE 310 SERIES

\*Available as flush or surface mounted



# THE 310 SERIES

We have kept **the 310 series** in production for many years because of its outstanding success with our customers. It is a lift car with the cleanest of lines, extremely versatile and adaptable, robust, hardwearing and now updated and available with an extensive series of optional extras. The safest possible bet for any serious building project.

## CAR CONSTRUCTION

- The lift cars in **the 310 series** are built in galvanised **sheet steel** finished with **high-pressure laminates** in a wide range of colours or in **stainless steel** with a choice of different textures.
- The **car lighting** can be direct using **LED spots** or **light panels**, or indirect using **fluorescent lights** with a range of different **suspended ceiling panels** available in attractive designs.
- The **car doors** are supplied with a **stainless steel finish in a choice of textures**, and the **car fronts** can also have a **stainless steel finish in a range of textures**, if required.
- The upper and lower **skirtings** are supplied with a **stainless steel finish** in a choice of textures.
- The car **flooring** can be finished in **hardwearing rubber**, in **granites** of various different shades, in **marble** and in other resistant materials such as **aluminium, stainless steel** or **reinforced vinyl**.
- **The handrails** are supplied with a stainless steel finish, in a range of different configurations, according to customer choice.
- **The mirror** can be supplied to fill **one-third, one-half** or **the entire width** of the car's rear wall, or we can supply the car **without a mirror**.

## THE 310 SERIES OFFERS

- **Great design and flexibility:** its excellent interior finishes and the wide range of colours and materials available for customer selection make **the 310 series** the ideal choice when looking for a top-quality lift car with a design standard to match.
- **Guaranteed durability.** **The 310 series** offers specially robust, long-lasting and hardwearing lift cars specially suitable for the transport of passengers and loads in hard job conditions
- **Rated loads available** to 1.275 Kg.
- **Simplicity:** the lift car is supplied with the lighting and operating panel pre-wired. Unit assembly is easy and quick, and each is delivered with all the detailed information and documentation required.
- **Added value:** every single lift car in **the 310 series** is completely assembled and then unassembled in our factory before on-site delivery, to ensure a perfect finish and trouble-free assembly.
- **Cars** suitable for lift systems compliant with the 2014/33/UE directive. Compliance with the EN 81-70, EN 81-71 and 81-72 standards, among others, is available on request.
- **Customized individual Design:** special car walls, floors, and ceiling finishes available on demand. Also available prepared to accept lighting or flooring by others.











THE 310 SERIES

# THE 350 | SERIES



 **IMEM**  
L I F T S



# THE 350 SERIES

The **350 series** offers the chance of ordering a completely unique and made-to-measure lift car. Customised according to the customer's tastes, tailored to suit the design style of the particular building, personalised with the company logo or emblem... the **350 series** offers all this and a whole lot more.

## CAR CONSTRUCTION

- The **350 series** lift cars are built with **galvanised steel sheeting** finished in **high-pressure laminates** available in a wide range of colours or in **stainless steel** with a choice of textures and with the rear wall finished with a **silkscreen-printed panel** to a design of the customer's choice and protected by a layer of **glass sheeting**.
- The **car lighting** can be direct using **LED spots** or **light panels**, or indirect using **fluorescent lights** with a range of different **suspended ceiling panels** available. The cars can be supplied **without lighting fittings**, should customers want to have them fitted themselves.
- The **car doors** are supplied with a **stainless steel finish in a choice of textures**, and the **car fronts** can also be finished in **stainless steel, in a range of textures**, as required.
- The upper and lower **skirtings** are supplied with a **stainless steel finish** in different textures.
- The **car flooring** can be finished in **hardwearing rubber**, in **granites** of various different shades, in **marble** and in other resistant materials such as **aluminium, stainless steel** or **reinforced vinyl**. Or it can be supplied **ready to be finished according to each customer's particular requirements**.
- The **handrails** are supplied with a stainless steel finish, in a range of different configurations, according to customer choice.

## THE 350 SERIES OFFERS

- **A completely unique lift car.** Travelling in the car and looking at the view outside, the skyline of a big city or your corporate emblem, will give your building its own unrepeatable character. Each customer can define the silkscreen-printed panel according with his preferences and tastes.
- **Guaranteed durability.** The **350 series** offers specially robust, long-lasting and hardwearing lift cars specially suitable for the transport of passengers and loads in hard job conditions.
- **Rated loads available** to 1.275 Kg.
- **Simplicity:** the lift car is supplied with the lighting and operating panel pre-wired. Unit assembly is easy and quick, and each is delivered with all the detailed information and documentation required.
- **Added value:** every single lift car in the **350 series** is completely assembled and then unassembled in our factory before on-site delivery, to ensure a perfect finish and trouble-free assembly.
- **Cars** suitable for lift systems compliant with the 2014/33/UE directive. Compliance with the EN 81-70 standard, among others, available on request.
- **Customized individual Design:** special car walls, floors, and ceiling finishes available on demand. Also available prepared to accept lighting or flooring by others.











# THE 550 | SERIES



THE 350 SERIES



# THE 550 SERIES

Our much-admired **550 series**, with its updated design, offers luxurious and sophisticated lift cars which combine the use of elegant and cutting-edge materials with stainless steel in various finishes. A classic triumphantly revived for demanding surroundings and impressive in its every detail.

## CAR CONSTRUCTION

- The **550 series lift cars** are built with **galvanised steel sheeting** faced with **stainless steel** and then finished in horizontally mounted **panels of high-pressure laminates** available in a wide range of colours and designs.
- The **car lighting** can be direct using **LED spots** or **light panels**, or indirect using **fluorescent lights** with a choice of attractive **suspended ceiling panels available**.
- The **car doors** are supplied with a **stainless steel finish in a choice of textures**, and the **car fronts** can also be finished in **stainless steel, in a range of textures**, as required.
- The upper and lower **skirtings** are supplied with a **stainless steel finish** in different textures.
- The **car flooring** can be finished in **hardwearing rubber**, in **granites** of various different shades, in **marble** and in other resistant materials such as **aluminium, stainless steel** or **reinforced vinyl**.
- The **handrails** are supplied with a stainless steel finish, in a range of different configurations, according to customer choice.
- The **mirror** can be supplied to fill **one-half** of the car's rear wall or its **entire width** (at 300mm from the floor), or we can supply the car **without a mirror**.

## THE 550 SERIES OFFERS

- **Luxury and comfort:** each car in **the 550 series** with its sophisticated design and carefully thought-out detailing adds an exclusive and de-luxe look to any setting.
- **Guaranteed durability.** **The 550 series** offers specially robust, long-lasting and hardwearing lift cars specially suitable for the transport of passengers and loads in hard job conditions.
- **Rated loads available** to 1.275 Kg.
- **Simplicity:** the lift car is supplied with the lighting and operating panel pre-wired. Unit assembly is easy and quick, and each is delivered with all the detailed information and documentation required.
- **Added value:** every single lift car in **the 550 series** is completely assembled and then unassembled in our factory before on-site delivery, to ensure a perfect finish and trouble-free assembly.
- **Cars** suitable for lift systems compliant with the 2014/33/UE directive. Compliance with EN 81-70 and EN 81-72 standards, among others, available on request.
- **Customized individual Design:** special car walls, floors, and ceiling finishes available on demand. Also available prepared to accept lighting or flooring by others.











# CAR FINISHES 310, 350 & 550

HIGH-PRESSURE LAMINATE WALLS

 P301	 P302	 P303	 P304	 P305
 P306	 P307	 P308	 P309	 P310
 P311	 P312	 P313	 P314	 P315
 P316	 P317	 P318	 P319	
 P320	 P321	 P322	 P323	



# CAR FINISHES

**310**, **350** & **550**

## FLOORING

### Rubber flooring

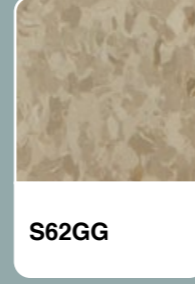
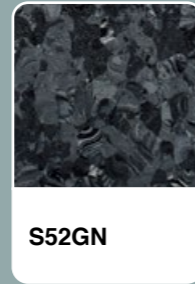
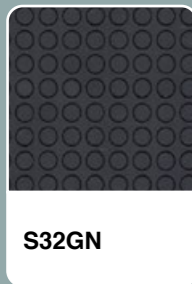

### Granite flooring

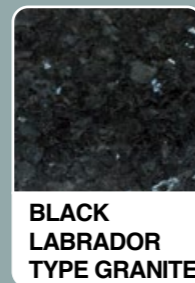
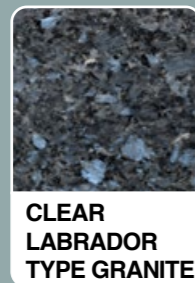
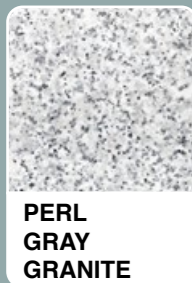

### Marble flooring

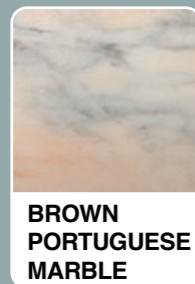
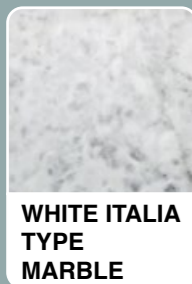

## CAR LIGHTING

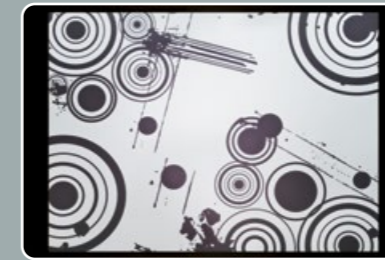
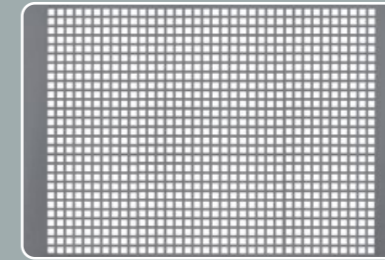

## STAINLESS STEEL HANDRAILS

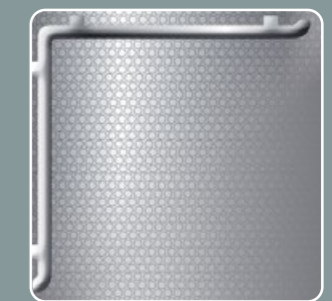

\* Available as RAL9005 sprayed or stainless steel executed



# OPERATION STATIONS, PUSH BUTTONS & INDICATORS

## CAR OPERATION PANEL

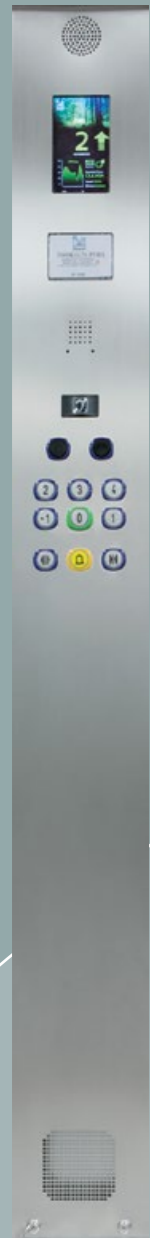

\*BC300

## LANDING OPERATION STATION



## SURFACE MOUNTED LANDING INDICATORS



## PUSH BUTTONS



## SPECIAL FUNCTIONS KEY SWITCHES



## FLUSH MOUNTED LANDING INDICATORS

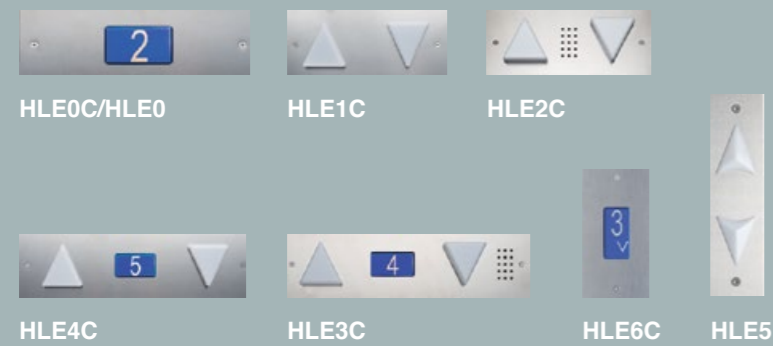

## DISPLAYS



\*Available as flush or surface mounted

# THE 710 SERIES





# THE 710 SERIES

Classical elegance. Timeless style. Tradition and craftsmanship. Feelings inevitably evoked by the 710 series lift car. Cars finished in beautiful hardwoods which add an inimitable warmth and richness to the very finest architectural surroundings.

## CAR CONSTRUCTION

- The 710 series lift car is built over a metal structure and finished with solid oak or chestnut panelling and trimmed with natural or gold-finished stainless steel, as required.
- The car lighting is direct using LED spots.
- The car doors are supplied with a stainless steel finish in a choice of textures, and the car fronts can also be finished in stainless steel, in a range of textures, as required.
- The lower skirting is of stainless steel with a gold finish.
- The car flooring can be finished in hardwearing rubber, in granites of various different shades, in marble and in other resistant materials such as aluminium, stainless steel or reinforced vinyl.
- The handrails are supplied finished in solid oak and with side details in natural or gold-finished stainless steel.
- Safety-glass mirror to the full height and width of the rear wall, timber-framed and with natural or gold-finished stainless steel detailing.

## THE 710 SERIES OFFERS

- **Timeless luxury:** the 710 series is so much more than just another lift car. The beauty of its materials, its classical style and its finely crafted finish make each car a unique little work of art.
- **Rated loads available** to 1.275 Kg.
- **Simplicity:** the lift car is supplied with the lighting and operating panel pre-wired. Unit assembly is easy and quick, and each is delivered with all the detailed information and documentation required.
- **Added value:** every single lift car in the 710 series is completely assembled and then unassembled in our factory before on-site delivery, to ensure a perfect finish and trouble-free assembly.
- **Cars** suitable for lift systems compliant with the 2014/33/UE directive.
- **Customized individual Design:** special car walls, floors, and ceiling finishes available on demand. Also available prepared to accept lighting or flooring by others.







# CAR FINISHES

## 710

### FLOORING

#### Granite

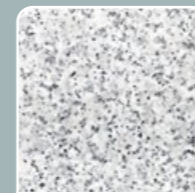

PERL  
GRAY  
GRANITE

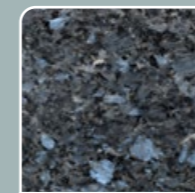

CLEAR  
LABRADOR  
TYPE GRANITE



BLACK  
LABRADOR  
TYPE GRANITE

#### Marble



WHITE ITALIA  
TYPE  
MARBLE



BROWN  
PORTUGUESE  
MARBLE

### WALLS

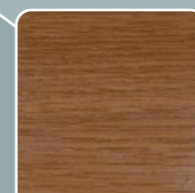

CHESTNUT 7101  
WITH GOLDEN  
STAINLESS  
STEEL

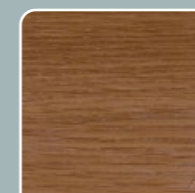

CHESTNUT 7101  
WITH  
STAINLESS  
STEEL

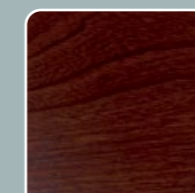

OAK WITH  
GOLDEN  
STAINLESS  
STEEL

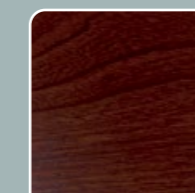

OAK WITH  
STAINLESS  
STEEL

### CAR LIGHTING



SPOT LED

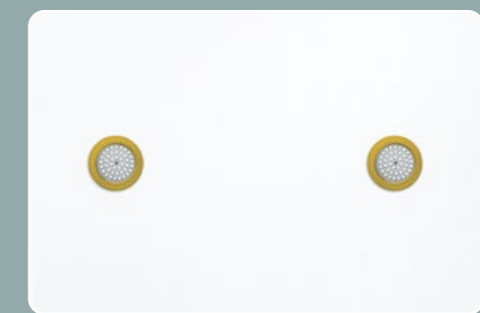

I LED

### CHESTNUT OR OAK HANDRAIL

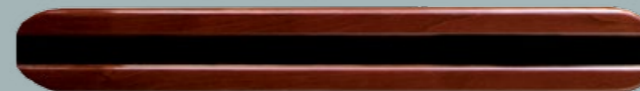



# OPERATION STATIONS, PUSH BUTTONS & INDICATORS

## CAR OPERATION PANEL

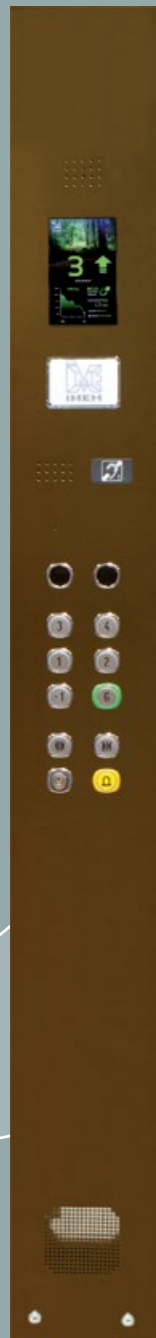

BC300

## DISPLAYS

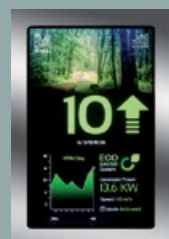

DCTFT (7")



DCEGH (5")



DCEPH



DEEPV

## LANDING OPERATION STATION



BEE1



BEE2



BEE3



BEE4



PEEN



PEIN



PEMT

## PUSH BUTTONS



PCEN



PCIN



PCEB



PCMT

## SURFACE MOUNTED LANDING INDICATORS



HLE1

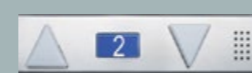

HLE3



HLE2

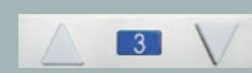

HLE4

## SPECIAL FUNCTIONS KEY SWITCHES



PCENK



PCMTK



PCSTK

## FLUSH MOUNTED LANDING INDICATORS

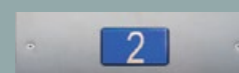

HLE0C/HLE0



HLE1C



HLE2C

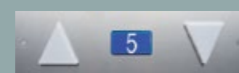

HLE4C



HLE3C

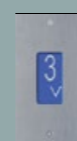

HLE6C



HLE5

# THE PANORAMIC SERIES





# THE PANORAMIC SERIES

Every one of our **panoramic lift cars** is designed to enhance the style and beauty of the building it serves. With their clean and graceful beauty, achieved with materials of the highest quality, our panoramic cars are strikingly impressive, a well-executed combination of elegance and precision engineering.

We manufacture every single **panoramic car** to order, and tailor it carefully to the tastes and preferences of each customer and the particular project in hand.

- We build **panoramic cars** for both indoor and outdoor use.
- **Available in all imaginable formats:** rectangular, polygonal, semicircular, circular or specially designed to suit the style and needs of each particular project.
- The **cars** can be **completely glazed** in Stadip 6+6 safety glass or **selectively glazed** with the glass framed in **stainless steel**.
- **Limitless design possibilities:** there is a wide range of materials available - stainless steel in different colours and textured finishes to match the glazing.
- **The car flooring** can be in marble, granite or in any other material the customer chooses.
- The cars can be fitted with **domes** in stainless steel and a range of different textures and formats as required to best suit the project.
- There is a wide choice of different designs for **car and landing operating panels, push-buttons, displays** and **direction of travel arrows**.
- **Options to personalise the lift cars** with a wide range of optional extras.
- **Glazed self-supporting structures** are available for both indoor and outdoor use.







M  
14  
Olympiades

Bir-Hakeim  
6



SQUARE

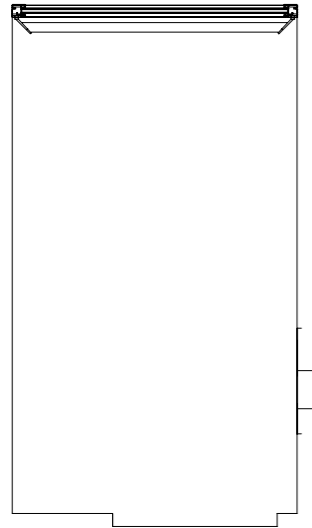

SR1

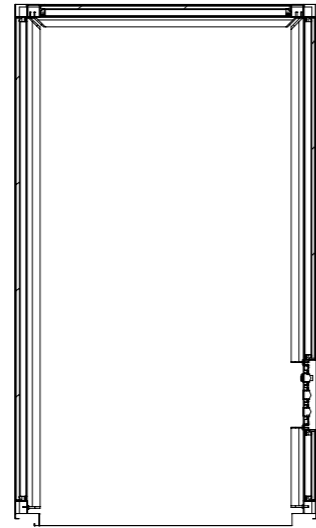

SR2

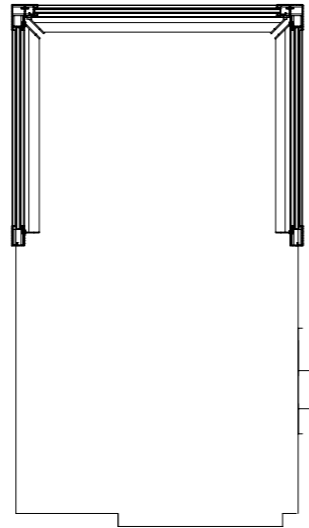

SR3

CIRCULAR

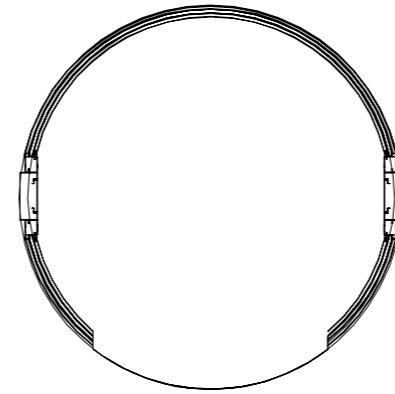

SC1

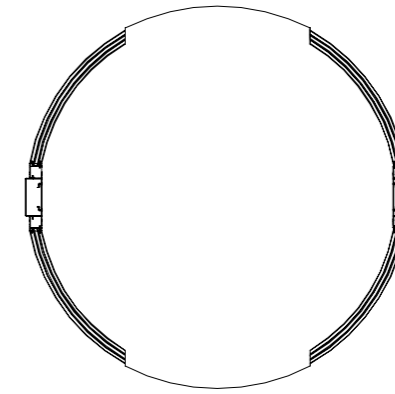

SC2

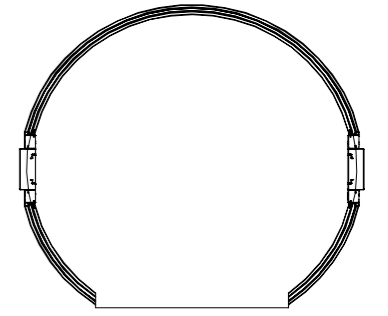

SC3

SEMI CIRCULAR

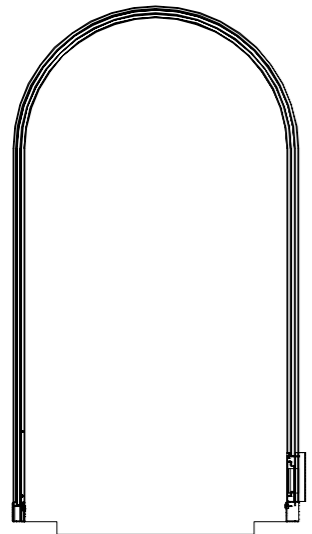

SSC1

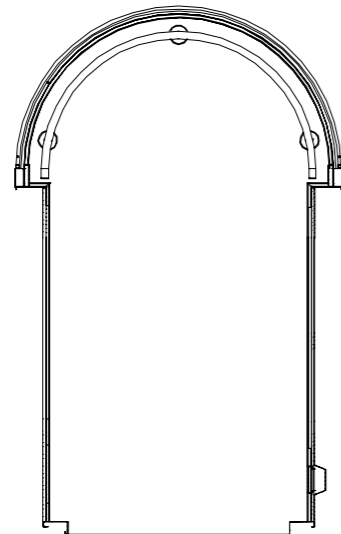

SSC2

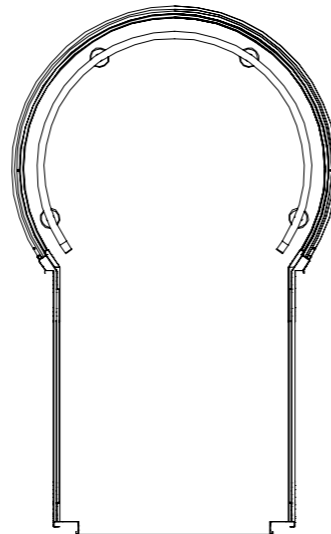

SSC3

POLYGONAL

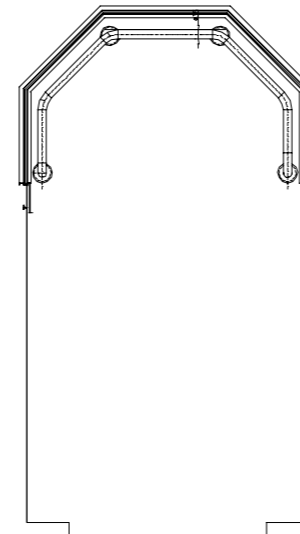

SP1

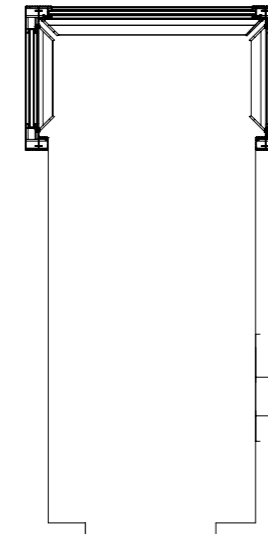

SP2

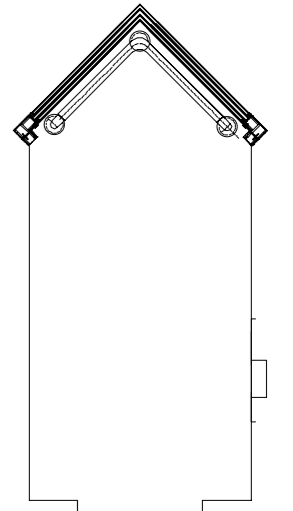

SP3



# DELIVERY TIMES



	320-630 Kg.	631-1.275 Kg.	1.300-2.000 Kg.	2.001-4.000 Kg.
210 Line	4 weeks	6 weeks	-	-
220 Line	-	-	8 weeks	10 weeks
310 Line	4 weeks	6 weeks	TBA	-
350 Line	6 weeks	6 weeks	-	-
550 Line	6 weeks	6 weeks	-	-
710 Line	6 weeks	6 weeks	-	-
Rectangular Panoramic Line	6 weeks	6 weeks	8 weeks	TBA
Panoramic Line (other models)	TBA	TBA	TBA	TBA

All the information contained in this catalogue is the property of **IMEM Lifts**. The partial or total reproduction of its contents without the prior written authorisation of **IMEM S.L.** is strictly forbidden. The distribution or copying of photographs, logos or any other graphic material contained herein is strictly forbidden, **IMEM Lifts** being the acknowledged sole proprietor of all intellectual property rights pertaining.

**IMEM Lifts** reserves the right to modify the specifications, options and colours presented in this catalogue. All the illustrations shown have a purely indicative character. The colours and materials of the delivered products may differ slightly from those in the catalogue.





Export Department  
C/ Adarzo 167-B  
39011 Peñacastillo - Santander (Spain)  
T. (00 34) 942 34 60 20 - F.(00 34) 942 35 53 64

[comex@imem.com](mailto:comex@imem.com)  
[www.imemlifts.com](http://www.imemlifts.com)



EFQM  
Business  
Excellence



ISO 9001  
Quality  
Management



OHSAS 18001  
Occupational  
Health & Safety  
Management



ISO 14001  
Environmental  
Management

